

Features

The *iQ* series generators are all built around our patent pending digital design. Compact in size, they provide the highest power density in the smallest package, while incorporating our exclusive flow through cooling. These generators are designed to handle the toughest applications and environments, capable of operating either in continuous duty or high-speed automation. Our industry leading 0.5 millisecond multi-core processing speed provides the highest level of accuracy and repeatability. The unique modular design allows for custom configurations and ultimate flexibility. This series is compatible with all your current Dukane hand probes, automation probes and converters.



Power and Frequencies from
600w to 4800w/40kHz–15Khz

Digital Features

- **100% digital control** of all power supply functions and parameters allows for unique configurations and future upgrades or requirements. Includes digital frequency synthesis.
- Industry leading data **acquisition rate speed of .5 ms** due to advanced **multi-core architecture**. Increased weld accuracy and repeatability.
- **Three step system safe power up sequence** 1) AC power inrush protection, 2) Supervisory System Monitor 3) Plug and Play configuration ID.
- **Digi-Trac** tuning automatically tracks the resonant frequency digitally. Adjust the output frequency to match the acoustic stack (sonotrode, booster, and transducer) this is done for every weld cycle and eliminates the need to manually tune the generator.
- **Ultrasonic overload protection**, with status indicator for ease of troubleshooting. The overload power limit is based on true RMS power output level.
- **Line Voltage Regulation** compensates for line fluctuations assuring consistent amplitude.
- **Temperature Drift Compensation** allows for seamless acoustic stack operation, and automatically compensates for acoustic stack temperature changes.
- **Patented Pulse-Width Modulation** design delivers power more efficiently with substantially less stress on the electrical and acoustic components for superior performance, reliability and extended life.
- **Linear Ramp Soft-start** algorithm allows the acoustic stack to be brought to operating amplitude smoothly, minimizing start-up surges and abnormal stress to the stack and power supply.
- **System Supervisory Monitors** checks all internal power supply functions for proper operation.
- **Load Regulation** provides constant ultrasound amplitude automatically regardless of the power draw. The ultrasonic output amplitude level is held to within 1 %, to provide weld process consistency and reduced weld cycle times.

FRONT

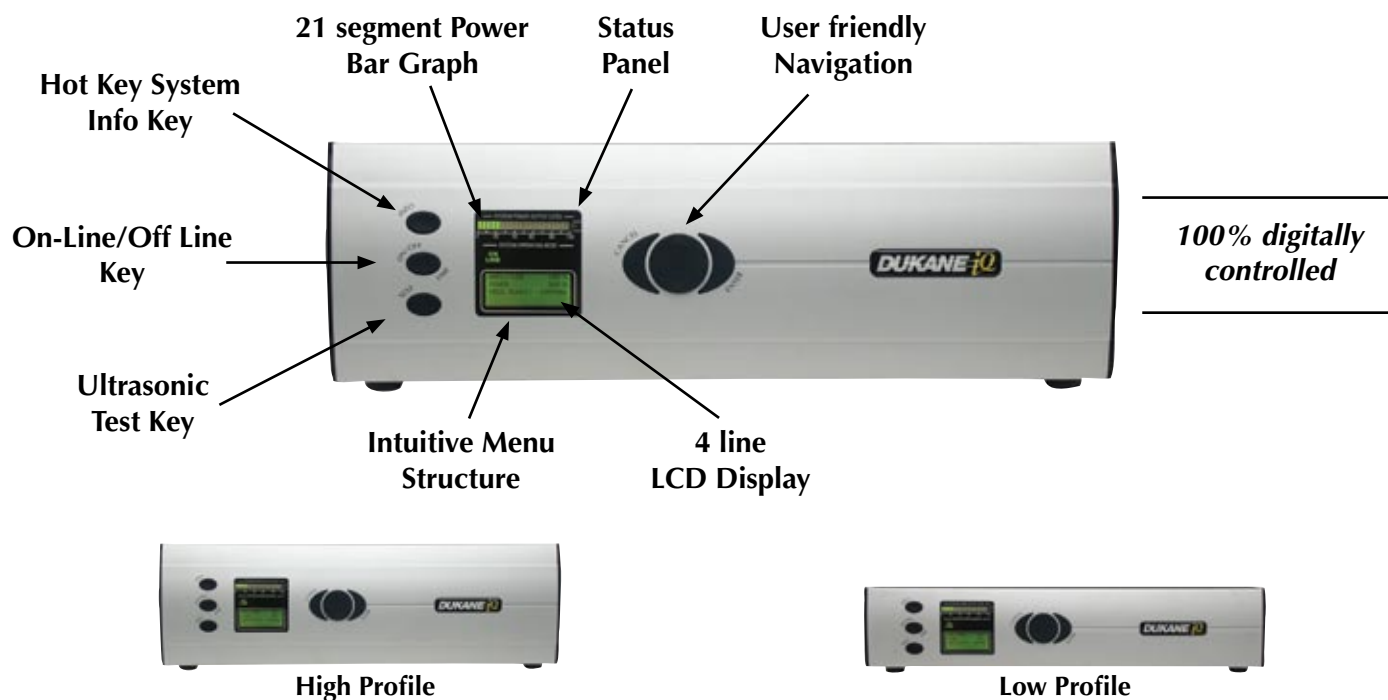

Mechanical Features

- **Flow Through Cooling** tunnel with a matched high performance heat sink and thermostatically controlled fan reduces thermal gradients, minimizes dirt infiltration and increases component life.



- **Highest power density** per unit of volume. Most power in the smallest package at highest duty cycle. Low and high profile configurations available.
- **21-segment multi-color power bar graph.** Peak power detect feature, LED remains on after weld cycle. Multifunction overload indicators. Ideal for quick diagnostics and troubleshooting.
- **4 line LCD** display with intuitive menu structure for quick easy programming.
- **RS232 serial configuration port** is used for field software upgrades, trouble shooting and advance hardware setup with optional PC based *iQ* configurator.

- **Advanced I/O is standard** with 25-pin output, and 15-pin input, user configurable from the utility menu. Visit: www.dukcorp.com/us go to **downloads/application notes** for your plastic assembly needs.
- Unique **Patent pending modular hardware design** incorporates motherboard/interconnect of internal components. Reduces internal cabling while increasing reliability and performance.
- **Rear panel expansion** slots are available to allow for custom configurations for OEM and cost effective custom solutions.

PART COUNT	44000	
GOOD	38940	88.5%
BAD	143	.3%
SUSPECT	4917	11.2%

- **Process statistics window** displays part count and % of good, bad and suspect welds.
- **System status panel** displays any of six self-diagnostic messages, including Fault, Input test, Overload, Overtemperature, On-line, or Off line.
- **Integrated frequency analyzer** accurately displays operating frequency of the acoustic stack. This is perfect for acoustic stack diagnostics.

BACK

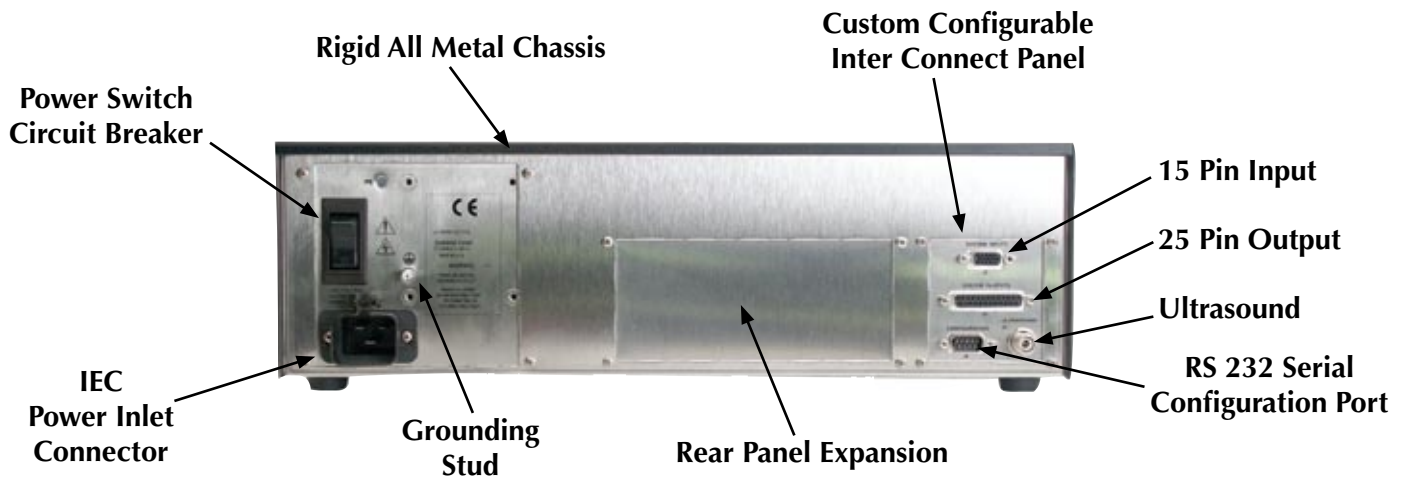

Mechanical Features. . .continued from previous page.

- **Standard 19" (48cm) Rack** mountable for easy system integration at minimal cost.
- **Compatibility** with all Dukane standard transducers, helps reduce inventory requirements and provides interchangeability with your existing DPC or Ultra series components.

Menu Controls

- Primary and secondary weld control parameters **Time, Energy, and Peak Power.**

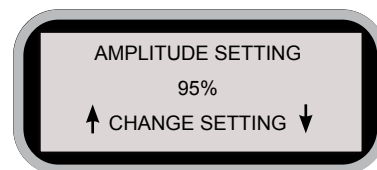
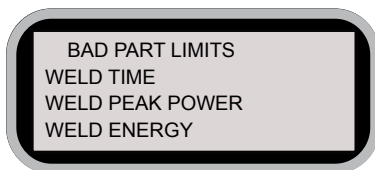

- **Bad and suspect process limits** include Time, Time and Energy, and Peak Power, with discrete outputs. These programmable limits provide the means to adapt to a wide variety of welding applications.
- **Amplitude adjustment** in 1% increments from 100% to 20%. through front panel or remote (4-20) mA.
- **16 setups** with individual user ID. (including Amplitude %)
- **Programmable softstart and softstop** amplitude can be used to reduce stress on acoustic stacks, or for high-speed application to achieve full amplitude in as short as .010 seconds. Factory configurable settings also available.
- **User-accessible programmable advanced hardware** settings allows changes to Phase Shift, Free Run Frequency, Frequency Lock/Hold and Frequency Limits – providing advance settings for difficult acoustic stacks.

- Selectable **frequency lock and hold** feature system ignores digi-trac automatic tuning feature and locks to startup stack frequency – helps in difficult applications where the stack couples with a product.
- **Programmable frequency bandwidth**, three selectable factory settings or user programmable windows for unique acoustic stacks and applications.
- **Afterburst control** includes delay and duration time settings

Options

- The user can select one of the following: Multi-probe Control (MPC), Automation Thruster Control, or Remote Amplitude. Additional module for converting isolated I/O from NPN (standard) to PNP is available.
- High or low profile package
- 19" rack mount brackets or vertical rear panel mount configurations are available for equipment cabinet installations.
- I/O configurations compatible with current DPC or Ultra series installations.



Vertical RearPanel Option

Dimensions

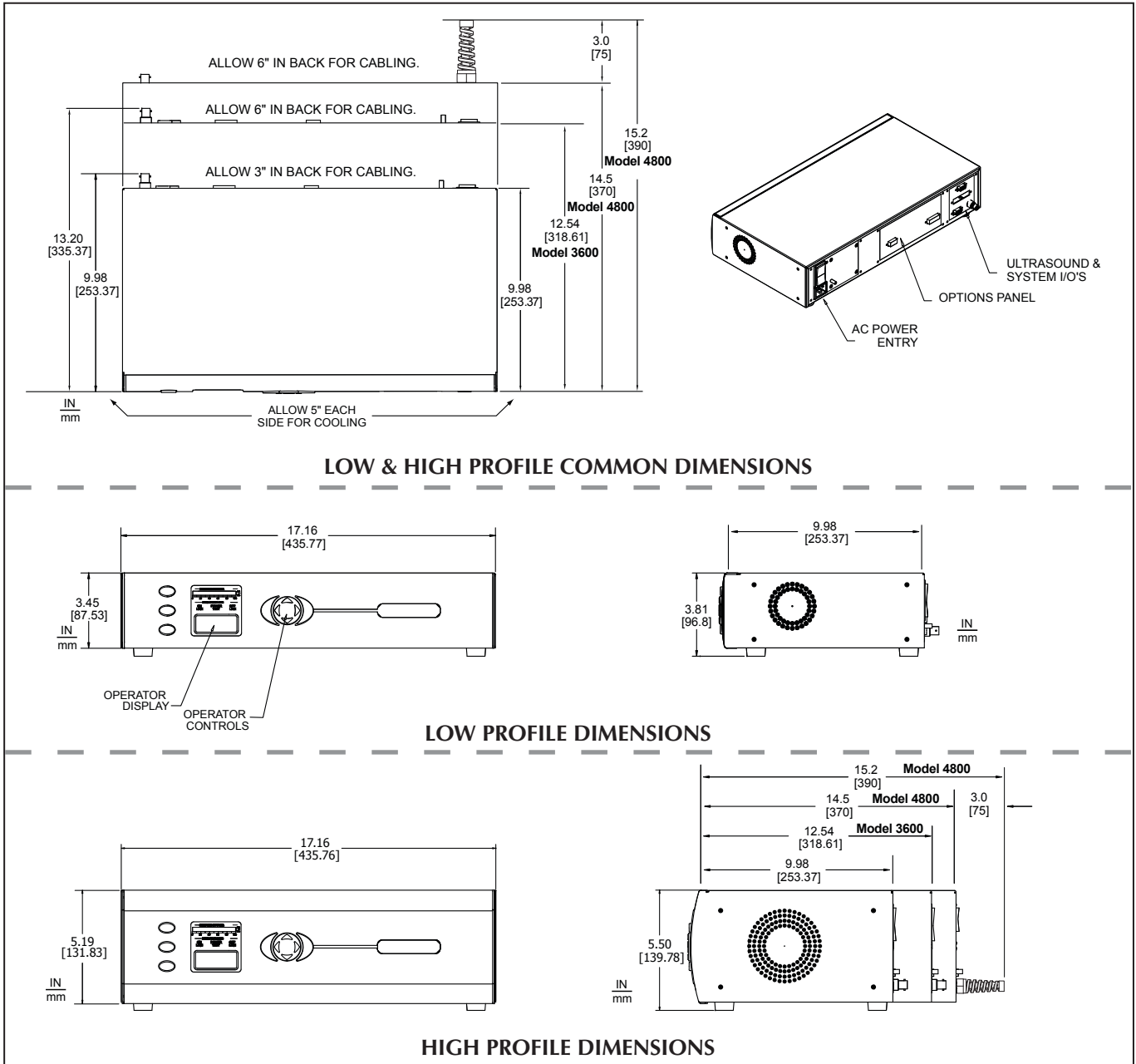

Approximate weight 25 lbs. Shipping weight 30 lbs. Wattage above 1200 requires 200-240 VAC, 50/60 Hz line.

MODELS

Power / Frequency / Profile	600 W	900 W	1200 W	1800 W	2400 W	3600 W	4800 W
15 kHz						H	H
20 kHz			H/L	H	H	H	H
30 kHz	H/L	H/L	H/L	H			
40 kHz	H/L	H/L	H/L				
Max. current:	10 amps	10 amps	15 amps	15 amps	15 amps	30 amps	30 amps
H = High Profile Chassis (H less than 1200 W fixed cord 100-120 VAC)			L = Low Profile Chassis (L only available in 200-240 VAC, 50/60 Hz)				

Note: All specifications are subject to change without notice. Please consult Dukane Ultrasonics for any updated information.